

DESIGN NOTES

3-Phase LTC3733 Provides High Performance Power Solutions for AMD Opteron and Athlon 64 Processors – Design Note 326

Henry J. Zhang and Wei Chen

Introduction

AMD Opteron™ and Athlon™ 64 CPUs can draw 65A at very low voltages (0.8V to 1.55V). Such high currents put efficiency and related thermal issues at the top of a power supply designer's list of problems. The new LTC3733 PolyPhase® synchronous buck controller solves these problems, and others, by enabling solutions that offer high efficiency, low profile and fast transient response.

The LTC3733 is a 3-phase current mode controller that drives three synchronous buck stages 120° out of phase. The three out-of-phase stages inherently self-cancel the current ripple and thus minimize the size of the input and output capacitors. Likewise, ripple cancellation and a high switching frequency (up to 600kHz) make it possible to use lower value output inductors, resulting in faster transient-load response and smaller physical inductor

size. The LTC3733's integrated MOSFET drivers also simplify the design and minimize the overall supply footprint. The LTC3733 directly senses the inductor current of each phase to achieve excellent current sharing among phases, thus evenly distributing the thermal stress. As a result, overdesign of the MOSFETs and inductors is unnecessary and the circuit can be operated reliably without a heat sink. The total size and cost of the solution is minimized.

The LTC3733 comes in a 36-Lead SSOP package and the LTC3733-1 comes in a low profile 7mm × 5mm QFN package with an exposed ground pad to minimize thermal impedance. An internal differential amplifier provides true

LTC, LT, Burst Mode and PolyPhase are registered trademarks of Linear Technology Corporation. Stage Shedding is a trademark of Linear Technology Corporation. All other trademarks are the property of their respective owners.

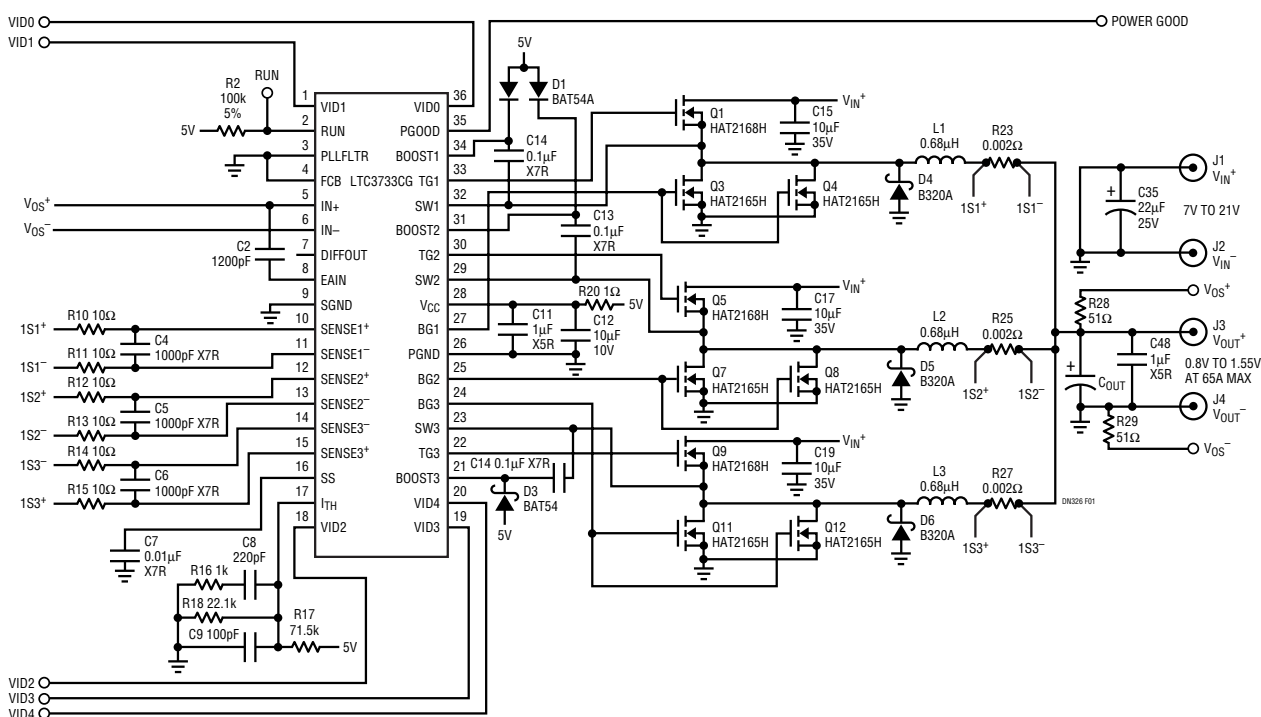

Figure 1. 65A AMD Processor Power Supply Using the LTC3733

remote sensing of the regulated supply's positive and negative output terminals at the load, providing accurate output regulation in high current applications. The internal 5-bit VID programmable attenuator complies with the AMD Opteron and Athlon 64 processors' VID table (0.8V to 1.55V). The LTC3733 also incorporates two selectable light load operation modes: Burst Mode[®] operation and Stage Shedding[™] mode to significantly improve light load efficiency. With internal overvoltage and overcurrent protection features, the resulting LTC3733 solution provides superior performance for a wide range of applications, from enterprise CPU to mobile CPU applications.

3-Phase, 65A AMD VRM Design

Figure 1 shows a 3-phase 65A AMD processor power supply. This supply achieves better than 88% efficiency for a 7V input and a 1.55V/65A output, as shown in Figure 2. Even for a 21V input, efficiency peaks at more

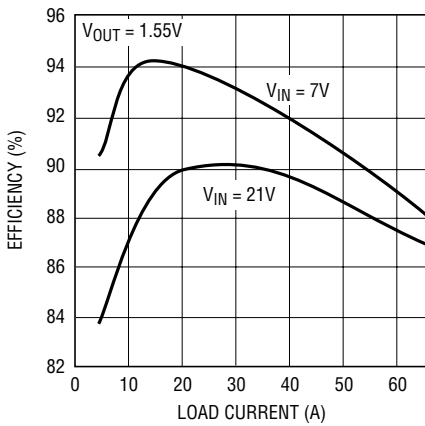

Figure 2. Efficiency vs Load Current at 7V to 21V V_{IN} , 1.55V V_{OUT}

than 90%, remaining high throughout a wide 5A to 65A load range.

Figure 3 shows a measured load transient waveform. The load current step is 46A with a slew rate of 50A/ μ s. Ten low profile Sanyo POSCAP capacitors (330 μ F/2.5V) are used on the VRM output. The maximum output voltage variation during the load transients is just 88mV_{p-p}.

Conclusion

The LTC3733-based low voltage, high current power supply meets the AMD processor VRM requirement. With 3-phase switching and superior light load operation modes (Stage Shedding and Burst Mode operation), this design can achieve high efficiency, small size and low overall solution cost. Accurate current sharing among the three phases improves thermal performance, and therefore, the long-term reliability of the CPU core power supply.

By combining the LTC3733 with one or more LTC3731s, a six or higher phase power supply can be easily obtained to power multiple CPUs. For more information, please contact Linear Technology Corporation.

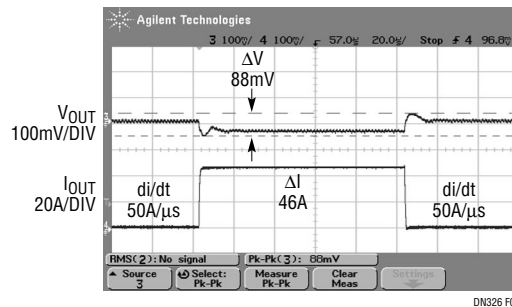

Figure 3. Load Transient Waveforms for a 46A Step with a 50A/ μ s Slew Rate

Data Sheet Download

<http://www.linear.com/go/dnLTC3733>

For applications help,
call (408) 432-1900, Ext. 2968